

Apr.1.2017 Copyright 2017 HIROSE ELECTRIC CO., LTD. All Rights Reserved.

1		2		3		4		5		6		7		8	
COUNT	DESCRIPTION OF REVISIONS	BY	CHKD	DATE	COUNT	DESCRIPTION OF REVISIONS	BY	CHKD	DATE	COUNT	DESCRIPTION OF REVISIONS	BY	CHKD	DATE	
△					△					△					
△					△					△					
△					△					△					

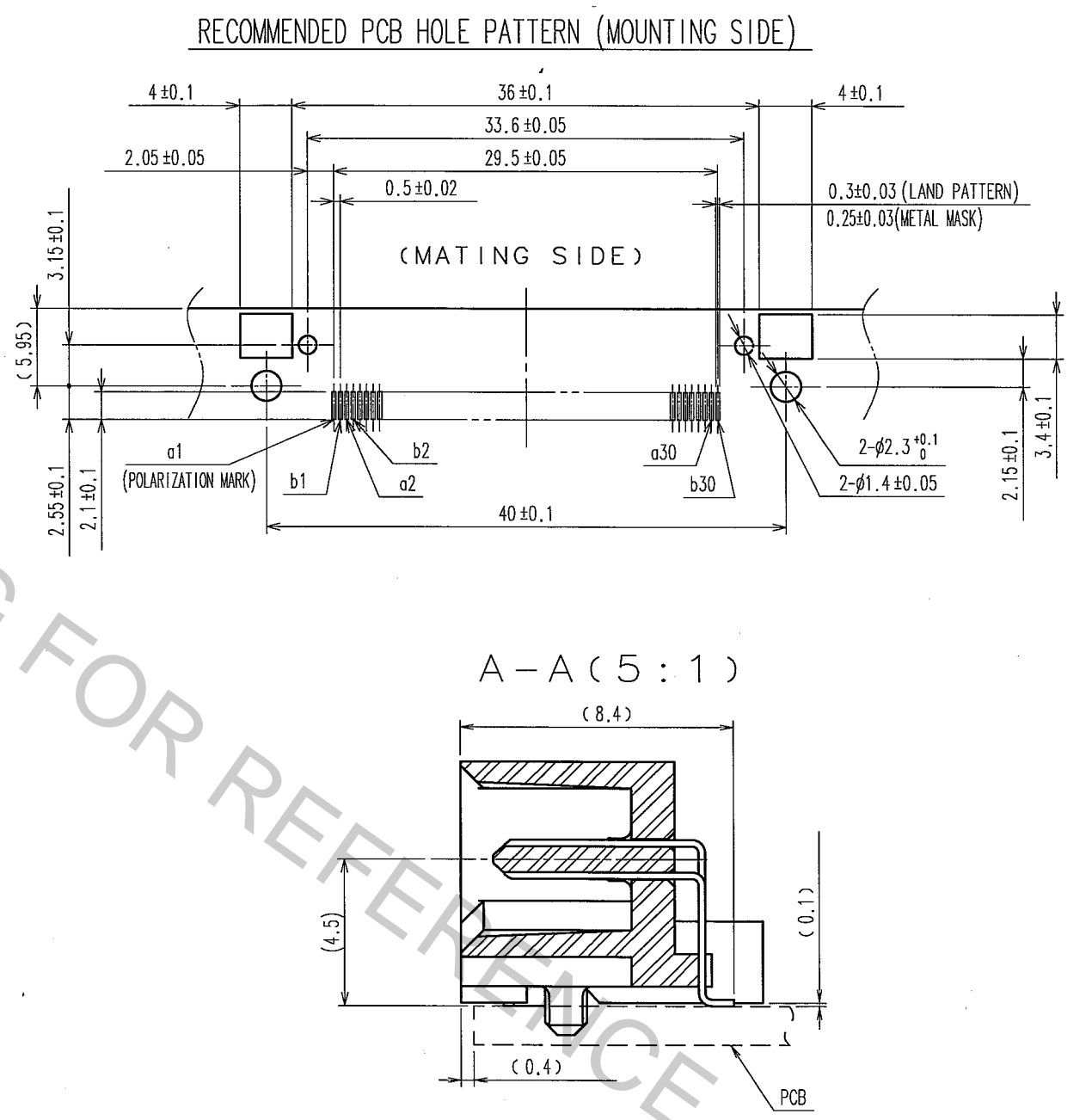
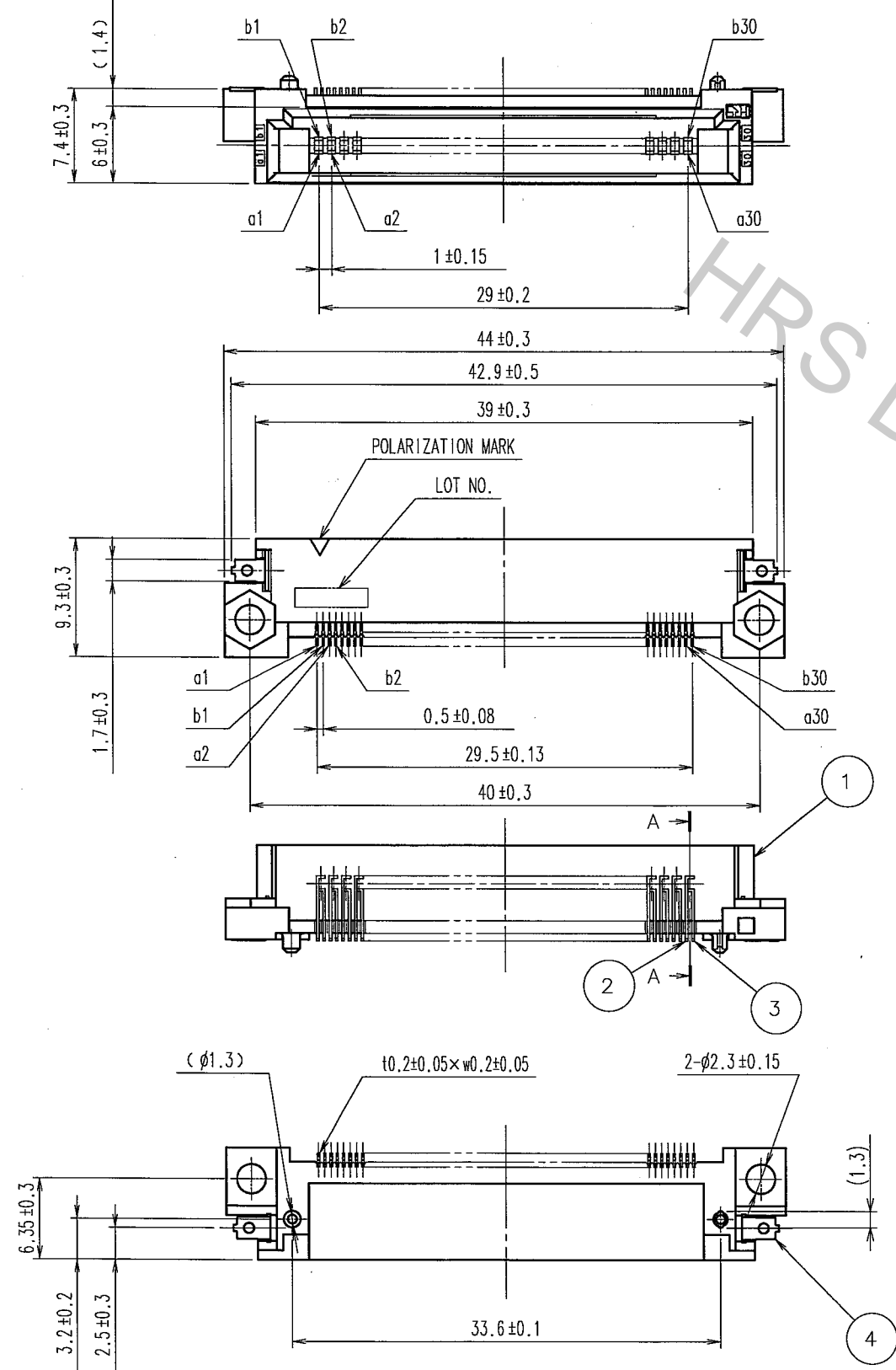

TO
PCK

NOTES 1. LEAD CO-PLANARITY INCLUDING REINFORCED METAL FITTINGS TO BE 0.1 MAX.
 2. NOTE THAT THE REFERENCE TIGHTENING TORQUE IS 0.15 N·m.
 3. THE DIMENSIONS IN PARENTHESES ARE FOR REFERENCE.

4	BRASS	TIN-PLATING	2, 3	BRASS	CONTACT AREA: GOLD 0.1μm min.
1	POLYAMIDE	BLACK UL94V-0			LEAD AREA: TIN-PLATING 1.2μm min.
					UNDER PLATING: NICKEL 1μm min.
NO.	MATERIAL	FINISH, REMARKS	NO.	MATERIAL	FINISH, REMARKS
CODE NO. (OLD) CL			DRAWN	DESIGNED	CHECKED
			A. SUZUKAWA	H. Nakamura	A. Ogawa
			06.09.01	06.09.01	06.09.01
DRAWING NO. EDC3-151934-22			PART NO. FX5-60P-SH09(91)		
SCALE 2:1			CODE NO. CL575-0057-1-91		
UNITS mm			HRS HIROSE ELECTRIC CO., LTD.		